

Specifications

AT 2900 RPM

PUMP MODEL	IN/OUT SIZE	Max. Capacity LPM	Max. Head Mtrs	MOTOR HP	FULL LOAD CURRENT	PHASE	Sp. Gr. Limit	WEIGHT
PMD-15	14 MM	15	2.5	0.10	0.15 Amps.	SINGLE	1.1	3 Kgs.
PMD-30	18 MM	30	4	0.16	0.20 Amps.	SINGLE	1.1	3.5 Kgs.
PMD-50	20 MM	50	5	0.25	0.50 Amps.	SINGLE	1.2	5 Kgs.
PMD-85	26 MM	85	9	0.50	1.00 Amps.	SINGLE/THREE	1.2	8 Kgs.
PMD-125	26 MM	125	12	0.75	1.25 Amps.	SINGLE/THREE	1.3	10 Kgs.
PMD-170	1" BSP	170	14	1.0	1.70 Amps.	THREE	1.3	12 Kgs.
PMD-300	1½" X 1¼"	300	22	1.5	2.40 Amps.	THREE	1.4	16 Kgs.

- All Pumps are rated for continuous duty with class E Insulation.
- Max operating Temp - 80°C for PP, 150°C for PVDF & 250°C for SS-316.
- All pumps are Centrifugal Semi-open impeller type pumps and need priming before start up.
- SS-316 Magnetic pumps are available upto 5 HP

Dimensions

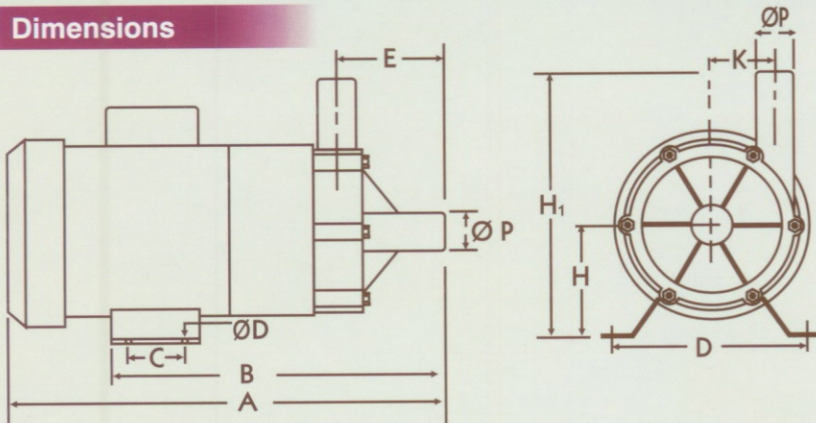

MODEL	A	B	C	D	E	H	H ₁	ØP	ØD	K	E
PMD-15	240	145	41	110	125	61	112	14	9	29	41
PMD-30	252	155	41	110	125	61	124	18	9	30	41
PMD-50	292	174	41	110	125	64	139	20	9	35	57
PMD-85	345	230	90	106	135	71	160	26	10	43	64
PMD-125	375	244	100	126	160	80	172	26	10	46	66
PMD-170	380	250	100	126	160	80	172	1"	10	46	50
PMD-300	400	270	100	126	160	85	185	1½x1¼"	10	58	57

Performance Curves

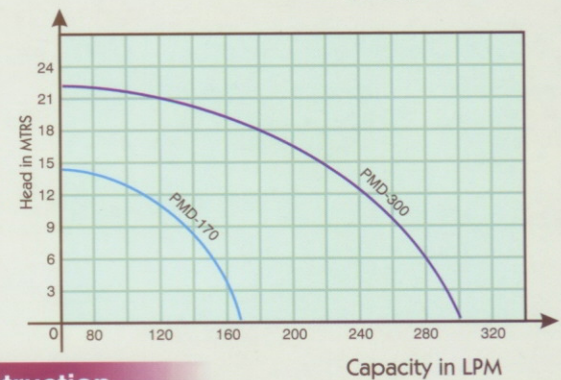
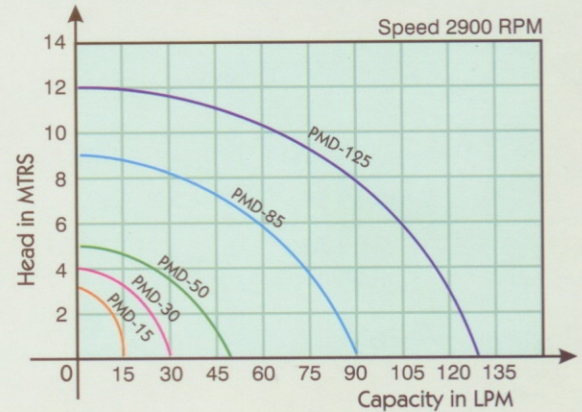

About Magnetic Pump

Magnetic drive design eliminates the conventional method of shaft coupling. Hence the pump casing is fully sealed from drive end which gives away the use of conventional sealing system. There is no seal used and hence no troublesome seal repairing and replacement, leakage and production lost. Impeller and drive magnets are permanent rare earth magnets. They prevent slippage and ensure that full motor horsepower is converted into pumping power.

Material of Construction

Part Name	PP Moc	PVDF Moc	SS-316 Moc
Suction Casing & Cover	GF-PP	PVDF	SS-316
Impeller	GF-PP	PVDF	SS-316
Impeller Shaft	High Alumina Ceramic	High Alumina Ceramic / Hast Alloy	SS-316
Bush	GFT / CFT	GFT / CFT	GFT / Si Carbon
Thrust washer	High Alumina Ceramic	High Alumina Ceramic / Hast Alloy	SS-316
O Ring	Viton	Viton	Viton
Magnets	Permanent High Power Rare Earth		
Mounting Bracket	Aluminum	Aluminum	Cast Iron
Motor Body	Aluminum	Cast iron	Cast iron

Manufactured & Marketed by

Authorised Dealer / Representative



Taha Pumps & Valves

Gujarat-363 035.